

STRAIGHT JACK CLAMP TYPE
CABLE 1/4" SUPERFLEXIBLE CORRUGATED

R161.232.007

Series : N

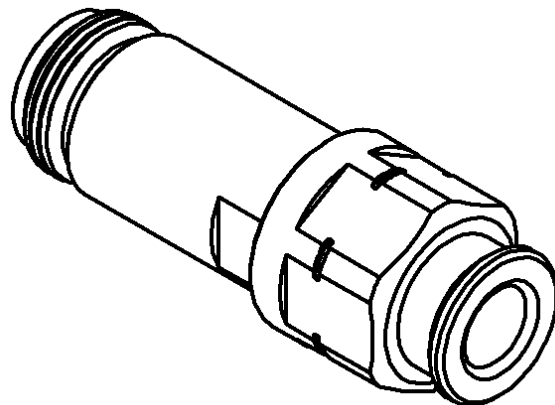
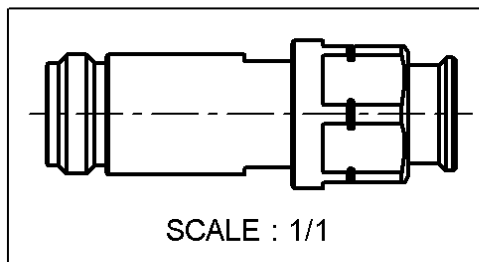
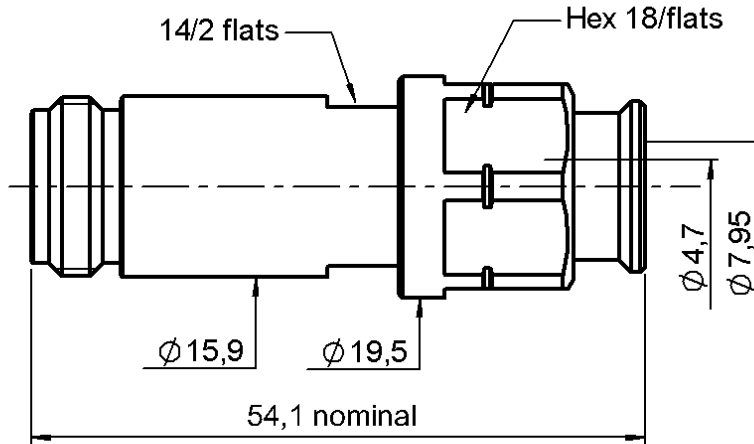

All dimensions are in mm.



COMPONENTS	MATERIALS	PLATINGS (µm)
BODY	BRASS	BBR 0.5 OVER SILVER 3
CENTER CONTACT	BERYLLIUM COPPER	SILVER 3 OVER COPPER 0.5
OUTER CONTACT	-	-
INSULATOR	PTFE	-
GASKET	SILICONE RUBBER	-
OTHERS PARTS	BRASS	BBR 0.5 OVER SILVER 3
-	-	-
-	-	-

Issue : 0220 C

In the effort to improve our products, we reserve the right to make changes judged to be necessary.



STRAIGHT JACK CLAMP TYPE
CABLE 1/4" SUPERFLEXIBLE CORRUGATED

R161.232.007

Series : N

PACKAGING

Standard	Unit	Other
50	'W' option	Contact us

SPECIFICATION

ELECTRICAL CHARACTERISTICS

Impedance		50	Ω
Frequency		0-11	GHz
VSWR	1.3 +	0.000	x F(GHz) Maxi
Insertion loss		0.048	\sqrt{F} (GHz) dB Maxi
RF leakage	- (101	- F(GHz)) dB Maxi
Voltage rating		850	Veff Maxi
Dielectric withstanding voltage		1500	Veff mini
Insulation resistance		5000	M Ω mini

CABLE ASSEMBLY

Stripping	a	b	c	d	e	f
mm	5.50	5.00	11.5	0.00	0.00	0.00

Assembly instruction :

Recommended cable(s)
FSJ1RN-50A - 1/4"
HCF 1/4" Cu2Y AlCu

Cable retention

- pull off	250	N mini
- torque	NA	N.cm

MECHANICAL CHARACTERISTICS

Center contact retention		
Axial force – Mating end	68	N mini
Axial force – Opposite end	68	N mini
Torque	NA	N.cm mini

Recommended torque		
Mating	NA	N.cm
Panel nut	NA	N.cm
Clamp nut	950	N.cm
A/F clamp nut	18.000	mm

Mating life	500	Cycles mini
Weight	62.766	g

TOOLING

Part Number	Description	Hexagon
.	.	.
R282.010.030	STRIPPING TOOL	
R282.303.220	TORQUE SPANNER .708 in 84.075 in.lb	

OTHERS CHARACTERISTICS

PIM3 < -155 dBc (-112 dBm) 2x20W

ENVIRONMENTAL

Operating temperature	-55/+105	$^{\circ}$ C
Hermetic seal	NA	Atm.cm3/s
Panel leakage	NA	

Issue : 0220 C

In the effort to improve our products, we reserve the right to make changes judged to be necessary.



STRAIGHT JACK CLAMP TYPE
CABLE 1/4" SUPERFLEXIBLE CORRUGATED

R161.232.007

Series : N

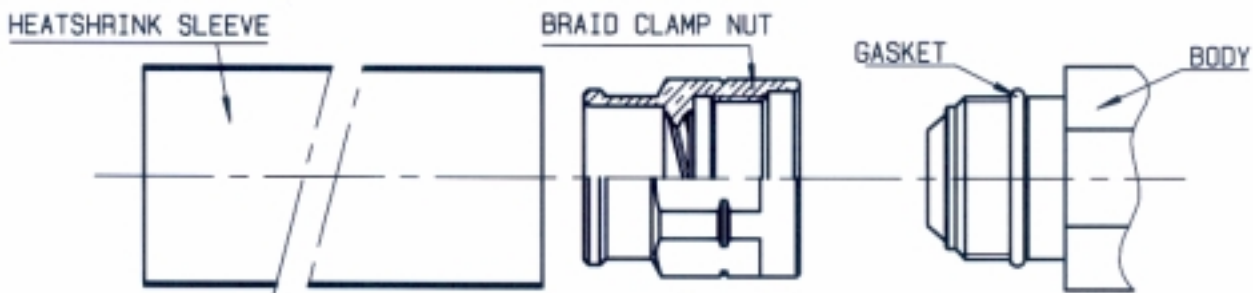

1

- Strip the cable
- Do not damage the outer conductor.
- Deburr cable inner conductor.

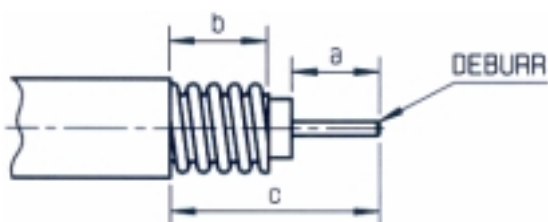

3

- Screw the connector onto the assembly.
- WARNING : Screw the connector on the braid clamp nut turning left (left-hand thread) so that the copper outer conductor is being squeezed.

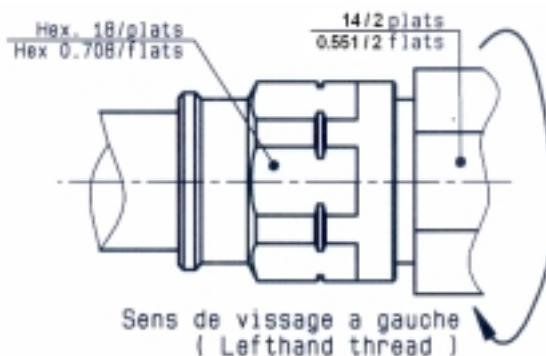

2

- Slide the heatshrink sleeve onto the cable.
- Screw manually the braid clamp nut onto cable outer conductor until stop.

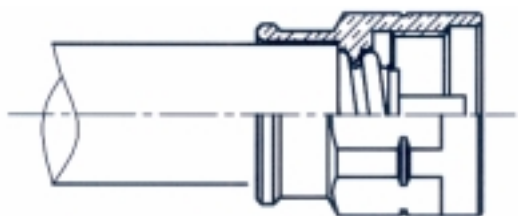

4

- Shrink the heatshrink sleeve.

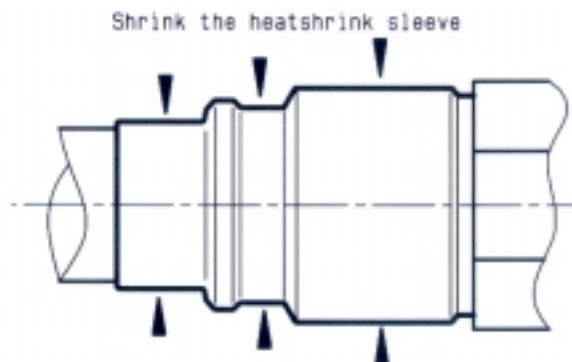

Issue : 0220 C

In the effort to improve our products, we reserve the right to make changes judged to be necessary.

