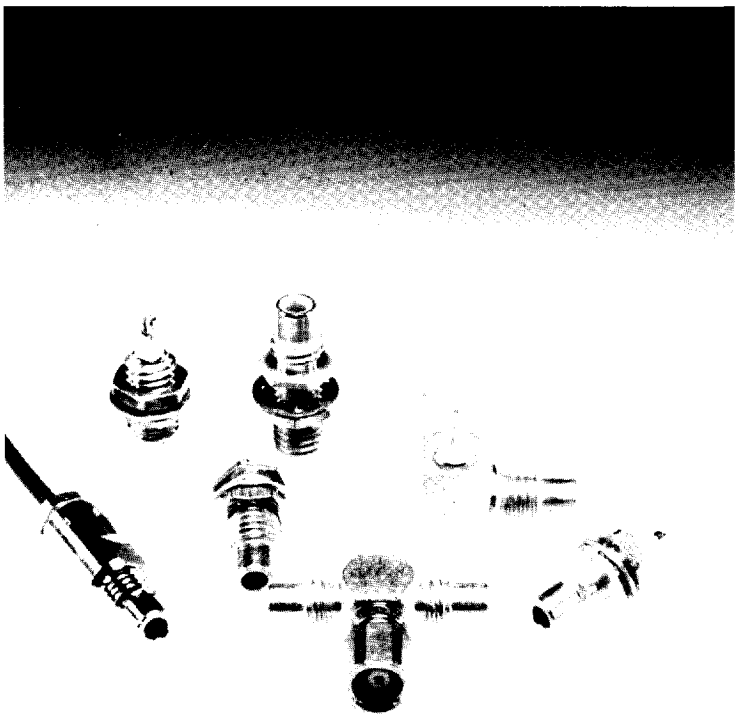

CONTENTS

	PAGE
General	3
Characteristics	4
Interface dimensions	5
For flexible cable, cable clamp type :	
Straight plug	6
Right angle plug	6
Straight jack	6
Bulkhead jack	6
For flexible cable, crimp type :	
Straight plug	7
Right angle plug	7
Straight jack	7
Bulkhead jack	7
For semi-rigid cable, direct solder type :	
Straight plug	8
Right angle plug	8
Torque wrench	8
Flange and bulkhead receptacle :	
Square flange receptacle	9
Bulkhead receptacle	9
Bulkhead receptacles :	
Hermetically sealed bulkhead receptacle	10
Right angle bulkhead receptacle	10
Receptacles for printed circuit board mounting .	
Straight PCB receptacle	10
Right angle PCB receptacle	10
In series adaptors :	
Female-Female	11
Male-Male bulkhead	11
Male-Male hermetically sealed bulkhead	11
Tee Male-Male/Female	11
Tee Male-Male/Male	11
Mounting instructions	12/17
Cable connector selection guide	18
Dimensions of applicable cables	18
Cross reference index	19
Chronological index by Radiall part number	19
Inter series adaptors	19

50 Ω

DC - 10 GHz

**GENERAL**

- Subminiature coaxial connectors
- Screw-on coupling
- Plugs have female contacts
- Jacks have male contacts
- Low weight
- Reduced outline dimensions

APPLICABLE STANDARDS

- MIL-C-39012

APPLICATIONS

- IF Systems
- Civil & Military Telecommunication
- Aeronautics
- Missiles
- Edge mounting applications

CHARACTERISTICS

REQUIREMENT	MIL - C - 39012 paragraph	GENERAL SPECIFICATIONS		
ELECTRICAL				
Impedance		50 Ω		
Frequency range		0 - 10 GHz		
V.S.W.R.	3 - 14	cable	2/50	2,6/50
		straight	1,25 +0,04 F (GHz)	1,20 +0,04 F (GHz)
		right angle	1,40 +0,06 F (GHz)	1,30 +0,04 F (GHz)
Insertion loss	3 - 27	straight	: 0,25 dB max. at 4 GHz	
		right angle	: 0,5 dB max. at 4 GHz	
			- 60 dB min. between 2 and 3 GHz	
RF leakage	3 - 26	1000 megohms min.		
Insulation resistance	3 - 11			
Contact resistance	3 - 16		Initial	After environment
		Centre contact (m Ω)	6	8
		Outer contact (m Ω)	1	1,5
Voltage rating (volts RMS)		cable 2/50 : at sea level	250 V, at 70000 ft	60 V
		cable 2,6/50 : at sea level	335 V, at 21000 m	85 V
Dielectric withstanding voltage	3 - 17	cable 2/50 : at sea level	750 V, at 70000 ft	185 V
		cable 2,6/50 : at sea level	1000 V, at 21000 m	250 V
RF high potential withstanding voltage (Frequency 5 MHz)	3 - 23	cable 2/50 : at sea level	500 V	
		cable 2,6/50 : at sea level	700 V	
MECHANICAL				
Life	3 - 15	500 matings		
Force to engage and disengage	3 - 5 - 1	torque : 16 inch-ounces max. - 11,3 Ncm		
Mating torque		35 to 50 inch-ounces - 25 to 35 Ncm		
Coupling nut proof torque		100 inch-ounces - 71 Ncm		
Coupling nut retention force	3 - 25	35 lbs. min. - 156 N min.		
Cable retention force	3 - 24	cable 2/50 : 13 lbs - 58 N and cable 2,6/50 : 25 lbs - 110 N		
Contact captivation		axial force : 4 lbs - 18 N. torque : not applicable.		
ENVIRONMENTAL				
Operating temperature range		standard models	: - 65°C + 165°C	
		hermetic	: - 65°C + 165°C	
		semi rigid cables	: - 65°C + 105°C	
Temperature cycling		MIL - STD - 202, method 102, condition C		
Thermal shock	3 - 20	MIL - STD - 202, method 107, condition B		
High temperature test		MIL - STD - 202, method 108		
Corrosion (salt spray)	3 - 13	MIL - STD - 202, method 101, condition B, 5%		
Vibration	3 - 18	MIL - STD - 202, method 204, condition D, 20 g		
Shock	3 - 19	MIL - STD - 202, method 213, condition C, 100 g		
Moisture resistance	3 - 21	not applicable		
Barometric pressure	3 - 22	MIL - STD - 202, method 105, condition C		
Hermetic test		down to 10 ⁻⁶ mm Hg (Torr)		
		leak rate	< 1 x 10 ⁻⁶ atm/cm ³ /sec	
MATERIALS				
Bodies and male contacts		brass, half hard per QQ - B - 626		
Female contacts and interfaces		beryllium copper per QQ - C - 530		
Ferrules		brass		
Insulators		PTFE teflon		
Gaskets		silicone rubber		
PLATING				
Body		gold to satisfy the corrosion requirements		
Centre contacts		gold		

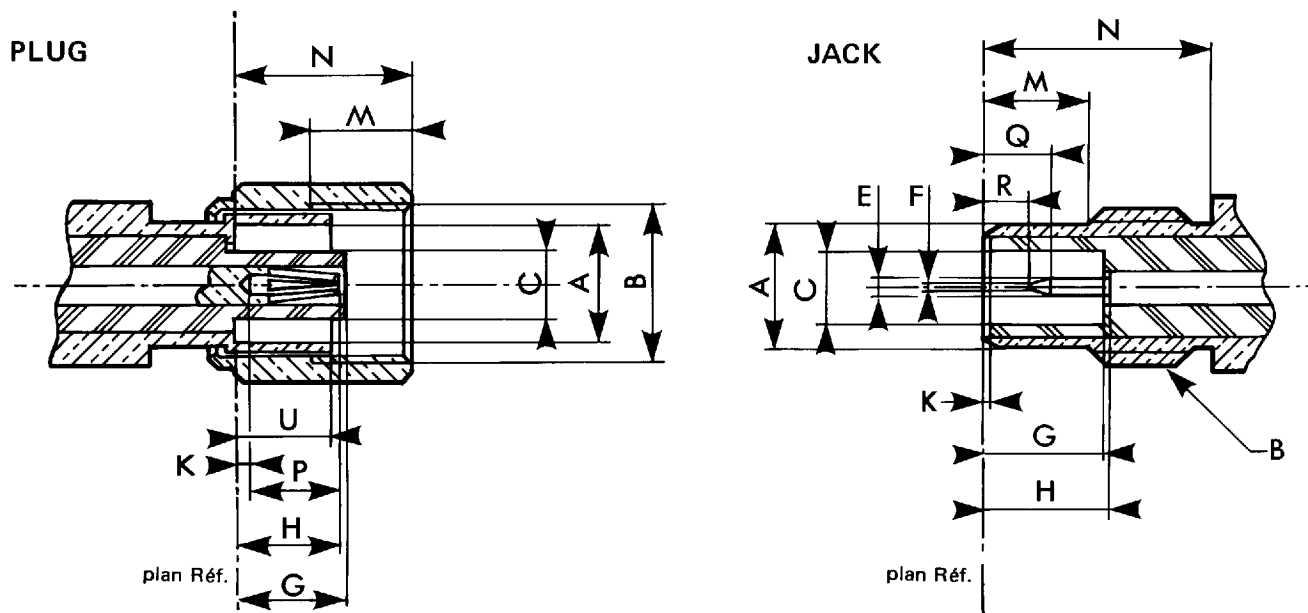

SMC

Letter	PLUG				JACK			
	mm		Inch		mm		Inch	
	min.	max.	min.	max.	min.	max.	min.	max.
Ø A	3,73	—	.147	—	—	3,71	—	.146
B	N° 10 - 32 UNF - 2 B				N° 10 - 32 UNF - 2 A			
Ø C	—	2,06	—	.081	2,08	—	.082	—
Ø E	—	—	—	—	0,48	0,53	.019	.021
Ø F	—	—	—	—	—	0,25	—	.010
G	—	3,40	—	.134	3,40	—	.134	—
H	—	3,40	—	.134	3,40	—	.134	—
K	—	—	—	—	000	—	000	—
M	2,79	—	.110	—	3,12	3,38	.123	.133
N	—	5,92	—	.233	5,94	—	.234	—
P	2,79	—	.110	—	—	—	—	—
Q	—	—	—	—	—	2,13	—	.084
R	—	—	—	—	0,61	—	.024	—
U	—	3,10	—	.122	—	—	—	—

STRAIGHT PLUG

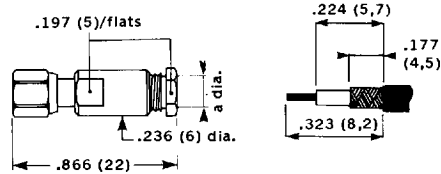
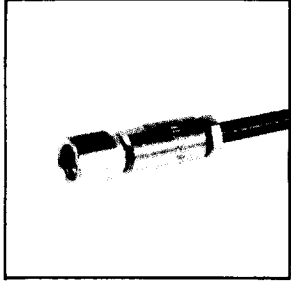

CABLE RG	178 B/U - 196 A/U	174 A/U - 188 A/U 179 B/U - 187 A/U
PART NUMBER	R 112 003	R 112 005
MIL no.	UG - 1460/U M39012/73-0003	UG - 1465/U M39012/73-0004
a dia.	.087 (2,2)	.118 (3)
Assembly	M 01	M 01

RIGHT ANGLE PLUG

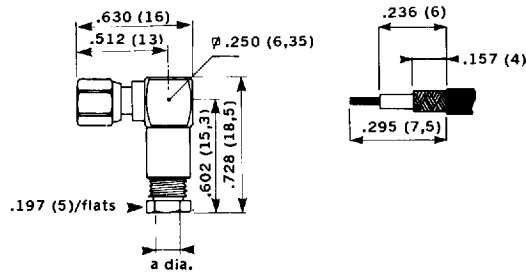
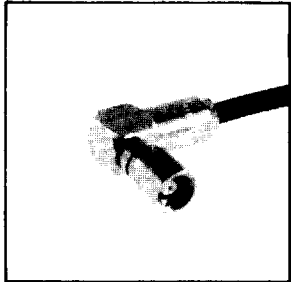

CABLE RG	178 B/U - 196 A/U	174 A/U - 188 A/U 179 B/U - 187 A/U
PART NUMBER	R 112 163	R 112 165
MIL no.	UG - 1461/U M39012/75-0003	UG - 1466/U M39012/75-0004
a dia.	.087 (2,2)	.118 (3)
Assembly	M 02	M 02

STRAIGHT JACK

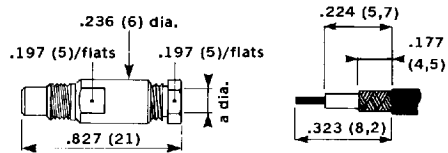
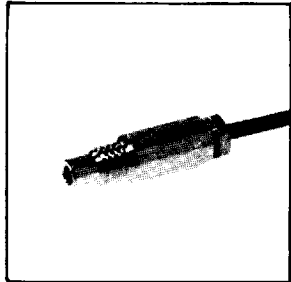

CABLE RG	178 B/U - 196 A/U	174 A/U - 188 A/U 179 B/U - 187 A/U
PART NUMBER	R 112 203	R 112 205
MIL no.	UG - 1462/U M39012/74-0003	UG - 1467/U M39012/74-0004
a dia.	.087 (2,2)	.118 (3)
Assembly	M 01	M 01

BULKHEAD JACK

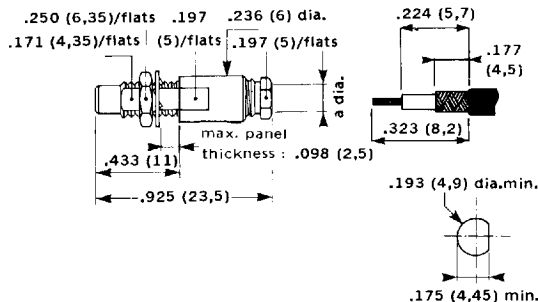
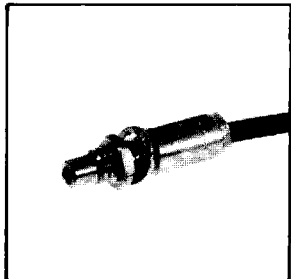

CABLE RG	178 B/U - 196 A/U	174 A/U - 188 A/U 179 B/U - 187 A/U
PART NUMBER	R 112 303	R 112 305
MIL no.	UG - 1463/U M39012/76-0003	UG - 1468/U M39012/76-0004
a dia.	.087 (2,2)	.118 (3)
Assembly	M 01	M 01

STRAIGHT PLUG

CABLE RG	178 B/U - 196 A/U	174 A/U - 188 A/U 179 B/U - 187 A/U
PART NUMBER	R 112 073	R 112 075
MIL no.	M 39012/73-0011	M 39012/73-0012
a dia.	.098 (2,5)	.126 (3,2)
Assembly	M 05	M 05

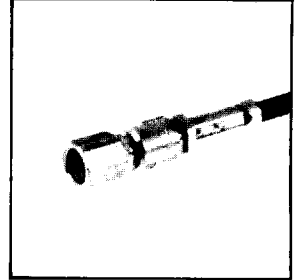
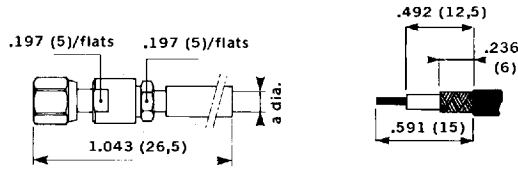

RIGHT ANGLE PLUG

CABLE RG	178 B/U - 196 A/U	174 A/U - 188 A/U 179 B/U - 187 A/U
PART NUMBER	R 112 183	R 112 186
MIL no.	M 39012/75-0011	M39012/75-0012
a dia.	.098 (2,5)	.126 (3,2)
Assembly	M 06	M 06

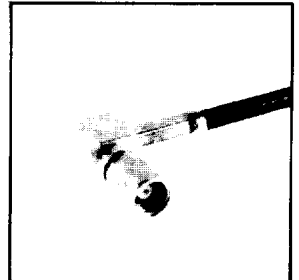
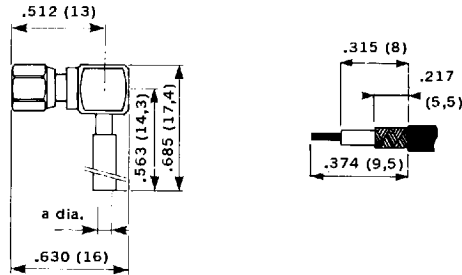

STRAIGHT JACK

CABLE RG	174 A/U - 188 A/U 179 B/U - 187 A/U
PART NUMBER	R 112 239
MIL no.	M39012/74-0012
Assembly	M 05

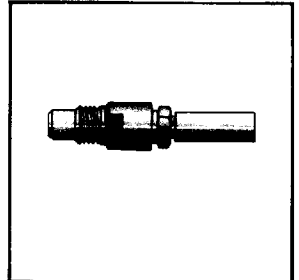
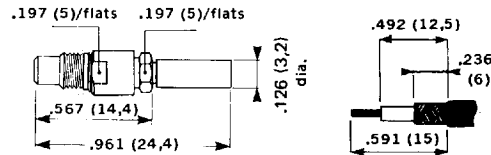

BULKHEAD JACK

CABLE RG	174 A/U - 188 A/U 179 B/U - 187 A/U
PART NUMBER	R 112 307
MIL no.	M 39012/76-0012
Assembly	M 05

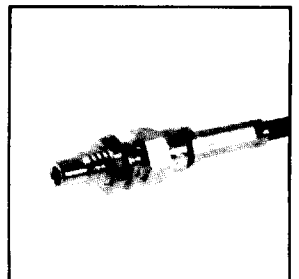
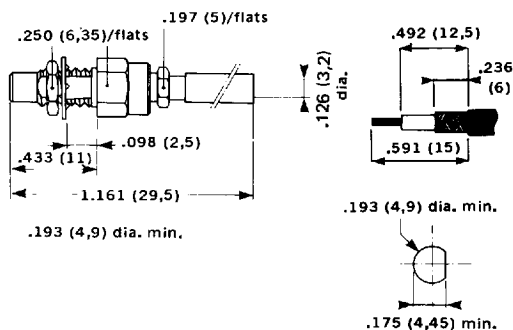

STRAIGHT PLUG

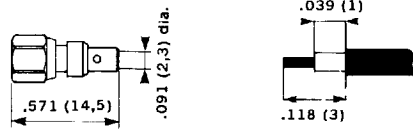
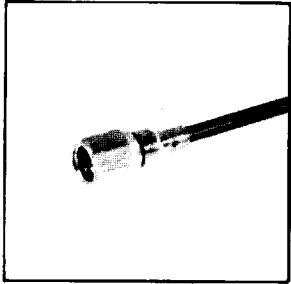

CABLE Ø	.085''
PART NUMBER	R 112 053
Assembly	M 03

RIGHT ANGLE PLUG

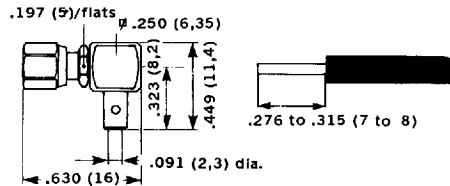
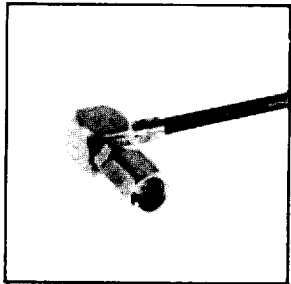

CABLE Ø	.085''
PART NUMBER	R 112 169
Assembly	M 04

TORQUE WRENCH : R 282 318

Torque : 35 to 50 inch-ounces - 25 to 35 Ncm.

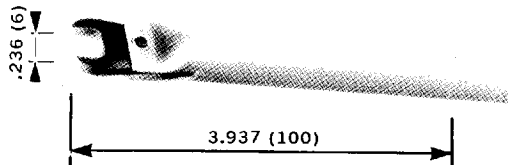

This torque wrench is preset to the recommended tightening torque and designed specifically for tightening the coupling nuts of plugs to the correct torque. Its use avoids damage to the interfaces and ensures good resistance to shock and vibration.

SQUARE FLANGE RECEPTACLE

PART NUMBER

R 112 403

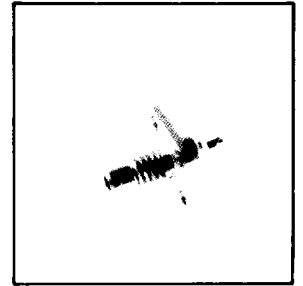
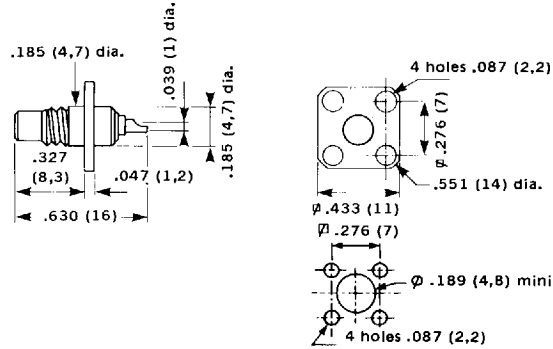

SQUARE FLANGE RECEPTACLE

PART NUMBER

R 112 413

Captive contact

NO + removable insulator

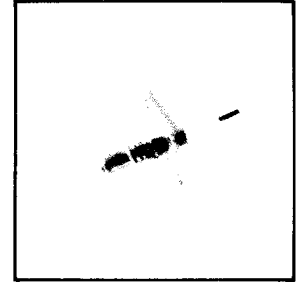
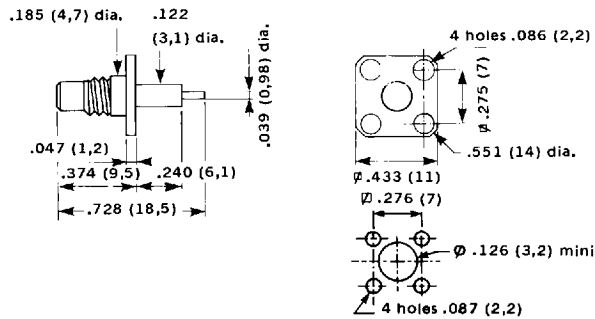

REAR NUT FIXING BULKHEAD RECEPTACLE

PART NUMBER

R 112 553

MIL no.

UG - 1464/U
M39012/77-0002

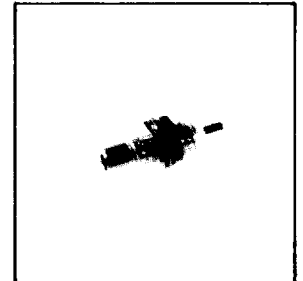
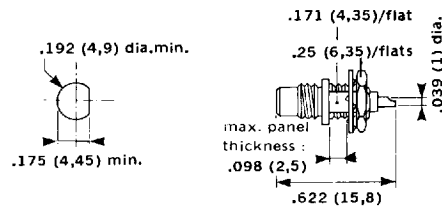

FRONT NUT FIXING BULKHEAD RECEPTACLE

PART NUMBER

R 112 554

MIL no.

UG - 1619/U
M39012/77-0001

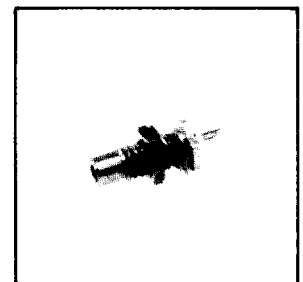
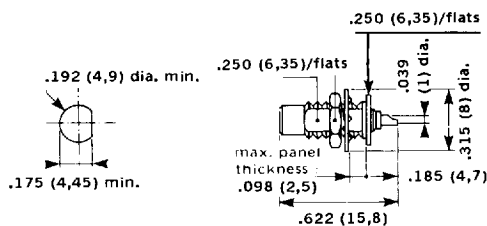

BULKHEAD RECEPTACLES

HERMETICALLY SEALED BULKHEAD RECEPTACLE FRONT NUT FIXING

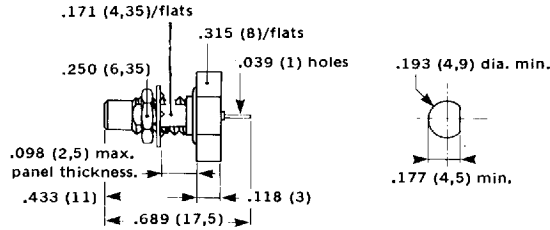
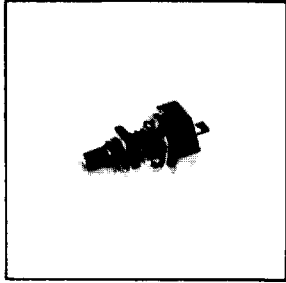

PART NUMBER	R 112 603
MIL no.	M39012/78-0001

RIGHT ANGLE BULKHEAD RECEPTACLE

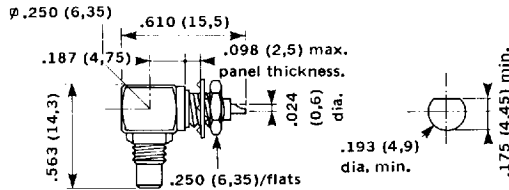
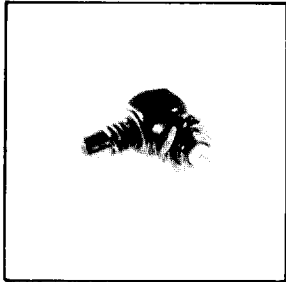

PART NUMBER	R 112 670
-------------	-----------

RECEPTACLES FOR PRINTED CIRCUIT BOARD MOUNTING

STRAIGHT PCB RECEPTACLE

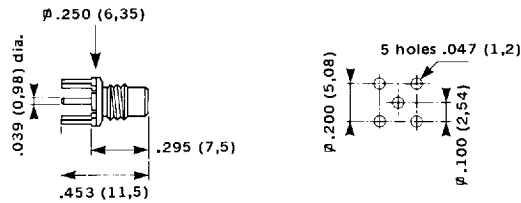
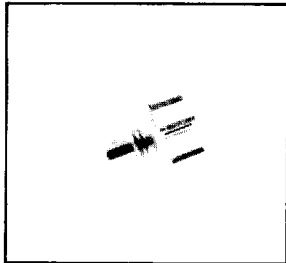

PART NUMBER	R 112 426
-------------	-----------

RIGHT ANGLE PCB RECEPTACLE

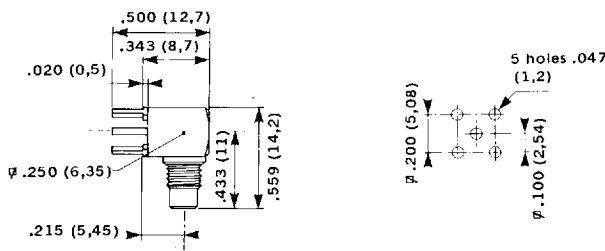
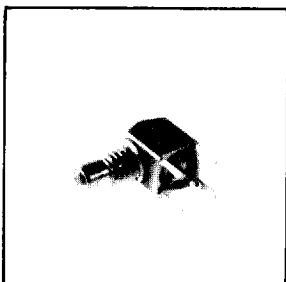

PART NUMBER	R 112 665
-------------	-----------

FEMALE - FEMALE (plug - plug)

PART
NUMBER

R 112 704

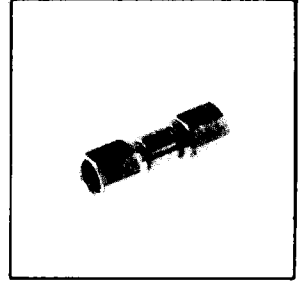
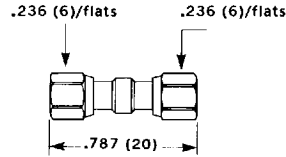

MALE - MALE BULKHEAD (jack - jack)

PART
NUMBER

R 112 720

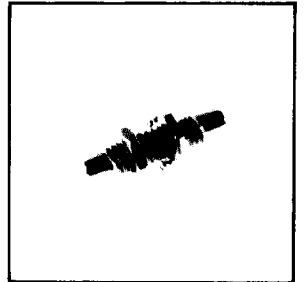
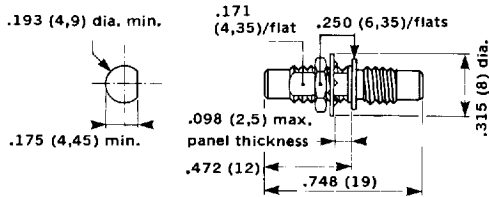

MALE - MALE HERMETICALLY SEALED BULKHEAD (jack - jack)

PART
NUMBER

R 112 753

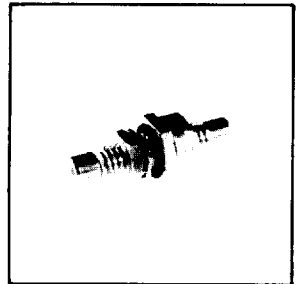
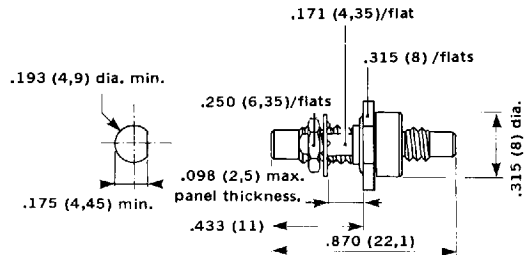

TEE MALE - MALE/FEMALE TEE MALE - MALE/MALE (jack - jack/plug) (jack - jack/jack)

PART
NUMBER

R 112 780 fig. A

R 112 781 fig. B

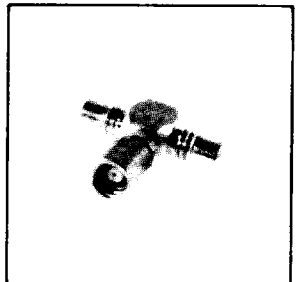
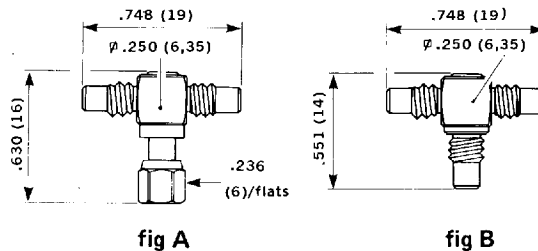

MOUNTING INSTRUCTIONS

M 01

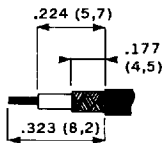
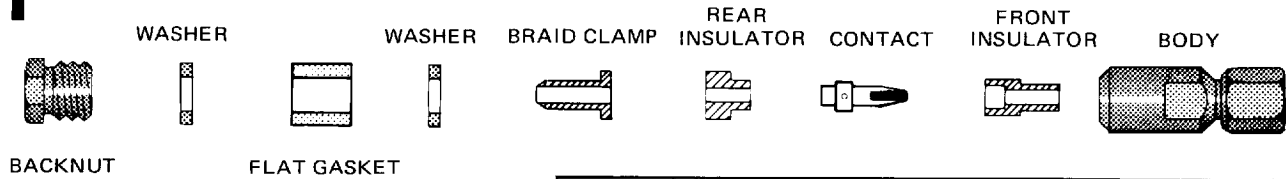

1

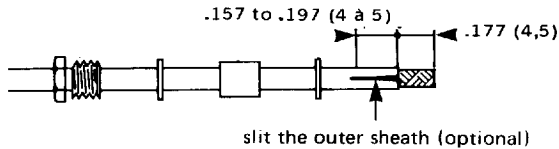

2

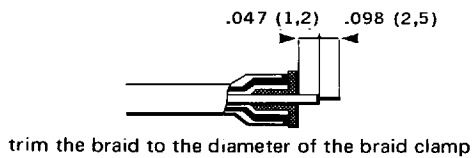

3

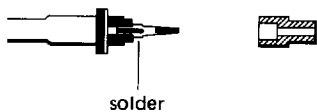

4



CONNECTORS	
R 112 003	In order to ensure good VSWR the plugs and jacks for 2,6/50 + 75 cables are supplied with 2 braid clamps : - for 2,6/50 cables use the knurled braid clamp. - for 2,6/75 cables use the smooth braid clamp.
R 112 005	
R 112 203	
R 112 205	
R 112 303	
R 112 305	

- 1 - 1 Slide the back nut, washer, gasket, washer over the cable.
1 - 2 Strip the cable.
1 - 3 Slit the sheath (optional) to ease positioning of the braid clamp under the braid.

- 2 - 1 Slide the braid clamp between the dielectric and the braid.
2 - 2 Trim the braid flush with the diameter of the braid clamp.
2 - 3 Cut the dielectric.

- 3 - 1 Fit the rear insulator.
3 - 2 Solder the contact.
3 - 3 Fit the front insulator over the contact.

- 4 - 1 Insert sub-assembly into the body.

MOUNTING INSTRUCTIONS

M 02

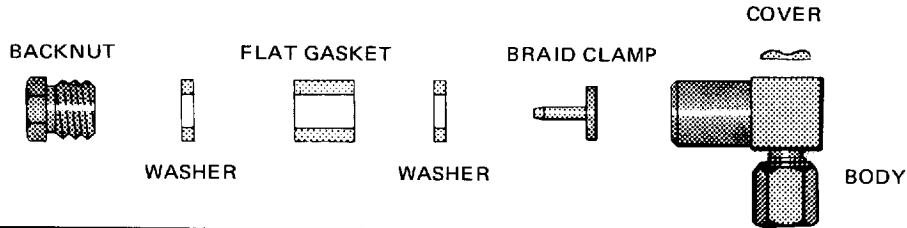

CONNECTORS	<p>In order to ensure good VSWR the plugs and jacks for 2,6/50 + 75 cables are supplied with 2 braid clamps :</p> <ul style="list-style-type: none"> - for 2,6/50 cables use the knurled braid clamp. - for 2,6/75 cables use the smooth braid clamp.
R 112 163 R 112 165	

- 1 - 1 Slide the back nut, washer, gasket, washer over the cable.
- 1 - 2 Strip the cable.
- 1 - 3 Slit the sheath (optional) to ease positioning of the braid clamp under the braid.

- 2 - 1 Slide the braid clamp between the dielectric and the braid.
- 2 - 2 Trim the braid flush with the diameter of the braid clamp.
- 2 - 3 Cut the dielectric.

- 3 - 1 Fit the sub-assembly into the body.

- 4 - 1 Solder the conductor in contact slot.
- 4 - 2 Fit cover in housing as shown.

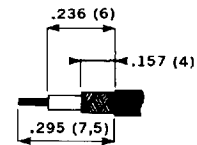

1

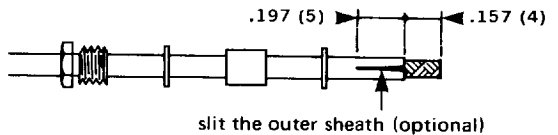

2

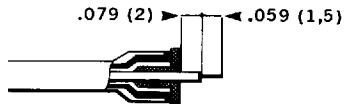

trim the braid to the diameter of the braid clamp

3

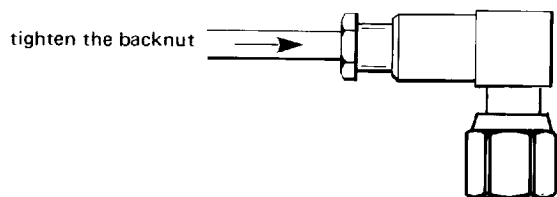

4

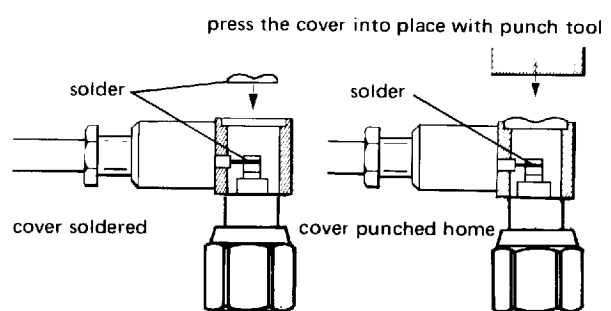

MOUNTING INSTRUCTIONS

M 03

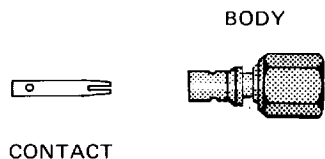

1

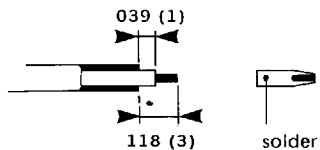

2



CONNECTOR
R 112 053

- 1 - 1 Cut the outer and dielectric.
- 1 - 2 Solder the contact.

- 2 - 1 Fit the sub-assembly into the body.
- 2 - 2 Solder the body onto the semi-rigid

NOTE : In order to ensure correct positioning of the contact it is recommended that a receptacle is fitted to the plug prior to soldering the body.

MOUNTING INSTRUCTIONS

MAIN HOUSING

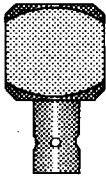

REAR INSULATOR

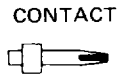

CONTACT

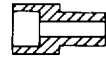

FRONT INSULATOR

FRONT BODY

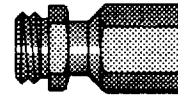

M 04

CONNECTOR

R 112 169

1

.276 to .315 (7 à 8)

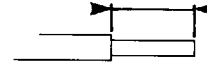

2

solder

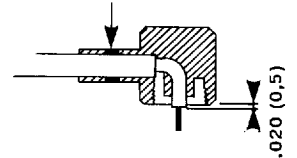

3

solder

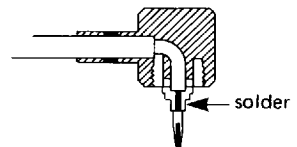

4

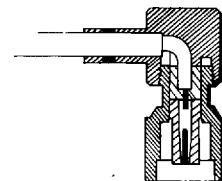

1 - 1 Cut off the outer.

2 - 1 Push the cable through the main housing.
2 - 2 Solder the body onto the semi-rigid.
2 - 3 Cut back the dielectric.

3 - 1 Fit the rear insulator.
3 - 2 Solder the contact ensuring that the contact has been pushed home into the rear insulator.

4 - 1 Fit the front insulator.
4 - 2 Fit the front body onto the sub-assembly.

MOUNTING INSTRUCTIONS

M 05

FERRULE

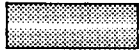

CRIMP BACKNUT



FRONT INSULATOR



CONTACT



BODY

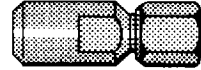

1

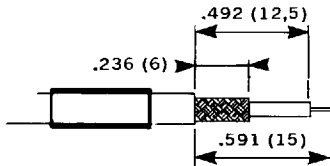

2

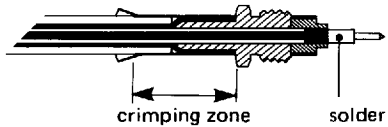

3



CONNECTORS	TOOLING	
R 112 073 R 112 075 R 112 239 R 112 307	RADIALL crimp tool	R 282 211
	or RADIALL tool	R 282 240
	+ RADIALL jaws	R 282 241
	or BUCHANAN tool	612 648
	+ BUCHANAN jaws	612 784
	2 mm Ø cable :	Hex. .105 (2,67)
	2,6 mm Ø cable :	Hex. .127 (3,25)

- 1 - 1 Slide the ferrule over the cable.
- 1 - 2 Strip the cable.
- 1 - 3 Open out the braid.

- 2 - 1 Slide the crimp backnut down between dielectric and braid.
- 2 - 2 Crimp the ferrule..
- 2 - 3 Solder the contact ensuring that the contact has been pushed has been pushed home into the rear insulator.

- 3 - 1 Fit the front insulator.
- 3 - 2 Insert sub-assembly into the body.

MOUNTING INSTRUCTIONS

M 06

CONNECTORS	TOOLING	
R 112 183 R 112 186	RADIALL crimp tool	R 282 211
	or RADIALL tool + RADIALL jaws	R 282 240 R 282 241
	or BUCHANAN tool + BUCHANAN jaws	612 648 612 784
	2 mm Ø cable :	Hex. .105 (2,67)
	2,6 mm Ø cable :	Hex. .127 (3,25)

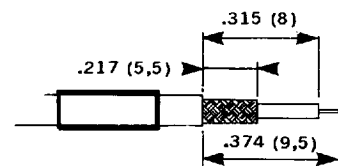
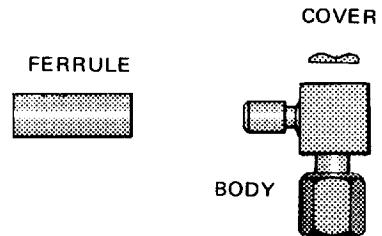

1

- 1 - 1 Slide the ferrule over the cable.
- 1 - 2 Strip the cable.
- 1 - 3 Open out the braid

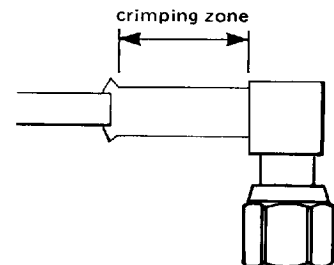

2

- 2 - 1 Slide the body down between dielectric and braid.
- 2 - 2 Crimp the ferrule.

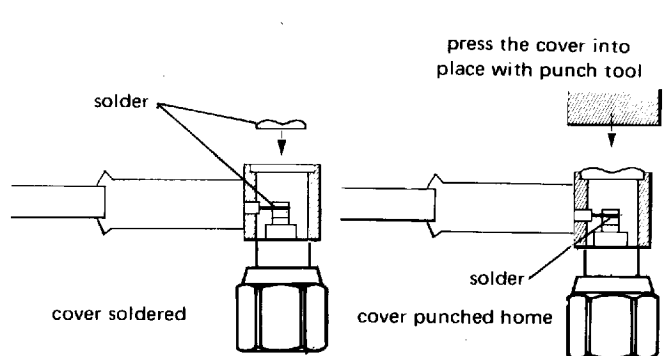

3

- 3 - 1 Solder the conductor in contact slot.
- 3 - 2 Fit cover in housing as shown.

CABLE - CONNECTOR SELECTION GUIDE

CABLES suitable for use with **RADIALL** connectors.

The cables are divided into cable groups defined by the approx. diameter in mm/impedance.

FLEXIBLE CABLES			SEMI-RIGID CABLES
2/50	2,6/50	2,6/75	.085
RG 178 B/U RG 196 A/U URM 110	RG 174 A/U RG 188 A/U RG 316/U URM 95 URM 109 URM 116	RG 179 B/U RG 187 A/U URM 111	RG 405/U

CABLE DIMENSION REFERENCE CHART

The following tables are presented as a convenient reference only.

For detailed specifications, refer to the relevant national or cable manufacturer's specifications.

All dimensions are nominal unless otherwise specified.

MIL-C-17-F

FLEXIBLE CABLES

CABLE TYPE	IMPEDANCE NOMINAL	DIMENSIONS Ø in inch and (mm)				CABLE GROUP	
		CENTRE CONDUCTOR		DIELECTRIC	BRAID		JACKET
		COMPOSITION	NOM.				
RG 174 A/U	50	7 x .006 (0,16)	.019 (0,48)	.060 (1,52)	.088(2,24) max.S	.110 (2,79)	.102 (2,6/50)
RG 178 B/U	50	7 x .004 (0,10)	.012 (0,30)	.033 (0,84)	.054(1,37) max.S	.071 (1,80)	.078 (2 /50)
RG 179 B/U	75	7 x .004 (0,10)	.012 (0,30)	.063 (1,60)	.084(2,13) max.S	.100 (2,54)	.102 (2,6/75)
RG 187 A/U	75	7 x .004 (0,10)	.012 (0,30)	.063 (1,60)	.084(2,13) max.S	.110 (2,79)	.102 (2,6/75)
RG 188 A/U	50	7 x .007 (0,17)	.020 (0,51)	.060 (1,52)	.081(2,06) max.S	.110 (2,79)	.102 (2,6/50)
RG 196 A/U	50	7 x .004 (0,10)	.012 (0,30)	.033 (0,84)	.054(1,37) max.S	.071 (1,80)	.078 (2 /50)
RG 316/U	50	7 x .007 (0,17)	.020 (0,51)	.060 (1,52)	.081(2,06) max.S	.098 (2,49)	.102 (2,6/50)

SEMI-RIGID CABLE

RG 405/U	50	solid	.020 (0,51)	.066 (1,68)		.087 (2,20)	.085
----------	----	-------	-------------	-------------	--	-------------	------

BS 2316 CABLES

FLEXIBLE CABLES

URM 95	50	solid	.018 (0,46)	.059 (1,50)	.077 (1,95) S	.091 (2,30)	.102 (2,6/50)
URM 109	50	7 x .007 (0,17)	.021 (0,54)	.059 (1,50)	.077 (1,95) S	.096 (2,45)	.102 (2,6/50)
URM 110	50	7 x .004 (0,11)	.013 (0,33)	.034 (0,87)	.052 (1,32) S	.071 (1,80)	.078 (2 /50)
URM 111	75	7 x .004 (0,11)	.012 (0,30)	.059 (1,50)	.077 (1,95) S	.096 (2,45)	.102 (2,6/75)
URM 116	50	7 x .006 (0,16)	.019 (0,48)	.059 (1,50)	.077 (1,95) S	.110 (2,79)	.102 (2,6/50)

CROSS REFERENCE INDEX

OF MILITARY AND NATIONAL SPECIFICATION NUMBERS TO RADIALL PART NUMBERS

MILITARY (UG-) NUMBER	RADIALL PART NO.	PAGE	MILITARY M 39012 NUMBER	RADIALL PART NO.	PAGE	NF REFERENCE	RADIALL PART NO.	PAGE
UG-1460/U	R 112 003	6	73-0003	R 112 003	6	KMV1	R 112 003	6
UG-1461/U	R 112 163	9	73-0004	R 112 005	6	KMV2	R 112 005	6
UG-1462/U	R 112 203	9	73-0011	R 112 073	7	KMV3	R 112 163	6
UG-1463/U	R 112 303	9	73-0012	R 112 075	7	KMV4	R 112 165	6
UG-1464/U	R 112 553	9	74-0003	R 112 203	6	KMV5	R 112 203	6
UG-1465/U	R 112 005	6	74-0004	R 112 205	6	KMV6	R 112 205	6
UG-1466/U	R 112 165	9	74-0012	R 112 239	7	KMV7	R 112 303	6
UG-1467/U	R 112 205	9	75-0003	R 112 163	6	KMV8	R 112 305	6
UG-1468/U	R 112 305	9	75-0004	R 112 165	6	KMV9	R 112 553	9
UG-1619/U	R 112 554	9	75-0011	R 112 183	7	KMV10	R 112 554	9
			75-0012	R 112 186	7	KMV11	R 112 670	10
			76-0003	R 112 303	6	KMV12	R 112 426	10
			76-0004	R 112 305	6	KMV13	R 112 665	10
			76-0012	R 112 307	7	KMV21	R 112 073	7
			77-0001	R 112 554	9	KMV31	R 112 075	7
			77-0002	R 112 553	9			

CHRONOLOGICAL INDEX BY RADIALL PART NUMBER

PART NUMBER	PAGE	PART NUMBER	PAGE
R 112 003	6	R 112 403	9
R 112 005	6	R 112 413	9
R 112 053	8	R 112 426	10
R 112 073	7	R 112 553	9
R 112 075	7	R 112 554	9
R 112 163	6	R 112 603	10
R 112 165	6	R 112 665	10
R 112 169	8	R 112 670	10
R 112 183	7	R 112 704	11
R 112 186	7	R 112 720	11
R 112 203	6	R 112 753	11
R 112 205	6	R 112 780	11
R 112 239	7	R 112 781	11
R 112 303	6		
R 112 305	6		
R 112 307	7		

INTER SERIES ADAPTORS

R 191 001 SMC male (jack) - APC7®
 R 191 003 SMC fem. (plug) - APC7®
 R 191 117 SMC male (jack) - BNC male
 R 191 120 SMC male (jack) - BNC fem./flange
 R 191 123 SMC fem. (plug) - BNC fem.
 R 191 141 SMC male (jack) - N male
 R 191 147 SMC fem. (plug) - N fem.

®APC7 - Bunker Ramo Amphenol