

**STRAIGHT PLUG CLAMP TYPE**

**R114.005.000**

**CABLE 2.6/50+75 S**

Series : SMB

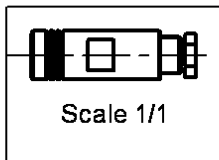
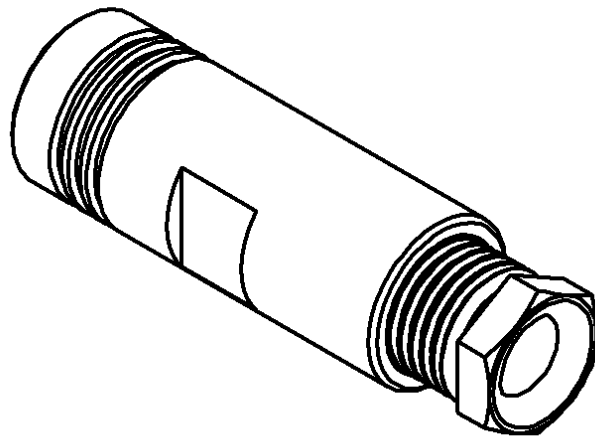
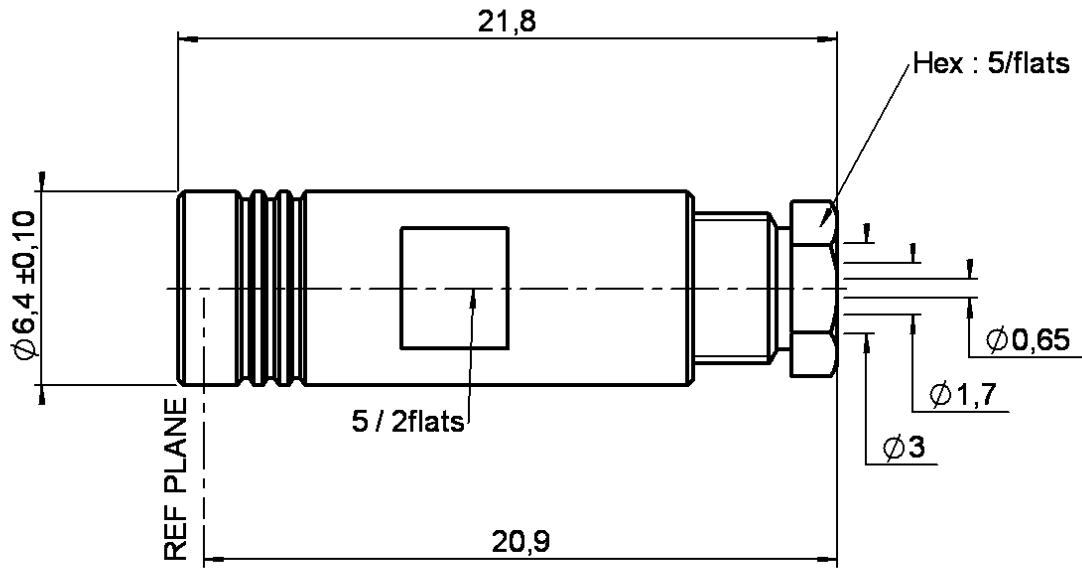

All dimensions are in mm.



COMPONENTS	MATERIALS	PLATINGS (µm)
BODY	BRASS	GOLD 0.2 OVER NICKEL 2
CENTER CONTACT	BERYLLIUM COPPER	GOLD 1.3 OVER NICKEL 2
OUTER CONTACT	BERYLLIUM COPPER	GOLD 0.5 OVER NICKEL 2
INSULATOR	PTFE	
GASKET	-	
OTHERS PARTS	BRASS	GOLD 0.2 OVER NICKEL 2
-	-	-
-	-	-

Issue : 0721 T

In the effort to improve our products, we reserve the right to make changes judged to be necessary.



**STRAIGHT PLUG CLAMP TYPE**

**R114.005.000**

**CABLE 2.6/50+75 S**

Series : SMB

**PACKAGING**

Standard	Unit	Other
<b>100</b>	<b>'W' option</b>	<b>Contact us</b>

**SPECIFICATION**

**QAE 06-02A**

**CABLE ASSEMBLY**

**ELECTRICAL CHARACTERISTICS**

Stripping	a	b	c	d	e	f
mm	2,50	0,00	4,50	4,50	1,20	0,00

Impedance	<b>50</b>	$\Omega$
Frequency	<b>0-4</b>	GHz
VSWR	<b>1.25 + 0,0400</b>	x F(GHz) Maxi
Insertion loss	<b>0.25</b>	$\sqrt{F}$ (GHz) dB Maxi
RF leakage	- ( <b>57</b> )	- F(GHz)) dB mini
Voltage rating	<b>335</b>	Veff Maxi
Dielectric withstanding voltage	<b>1000</b>	Veff mini
Insulation resistance	<b>1000</b>	M $\Omega$ mini

Assembly instruction :

Recommended cable(s)

RG 316  
 RG 187  
 RG 188  
 KX 22A  
 RG 179  
 RG 174  
 KX 3B  
 RG 174 FTX  
 RG 174  
 RG 316  
 ECO 316  
 K02252D  
 ECO 316 D

**MECHANICAL CHARACTERISTICS**

Center contact retention		
Axial force – Mating end	<b>10</b>	N mini
Axial force – Opposite end	<b>10</b>	N mini
Torque	<b>NA</b>	N.cm mini

Cable retention

- pull off	<b>110</b>	N mini
- torque	<b>NA</b>	N.cm

Recommended torque		
Mating	<b>NA</b>	N.cm
Panel nut	<b>NA</b>	N.cm
Clamp nut	<b>40</b>	N.cm
A/F clamp nut	<b>5,0000</b>	mm

**TOOLING**

Part Number	Description	Hexagon
.	.	.

Mating life	<b>500</b>	Cycles mini
Weight	<b>3,0000</b>	g

**OTHERS CHARACTERISTICS**

**ENVIRONMENTAL**

Operating temperature	<b>-65/+165</b>	$^{\circ}$ C
Hermetic seal	<b>NA</b>	Atm.cm3/s
Panel leakage	<b>NA</b>	

Issue : 0721 T

In the effort to improve our products, we reserve the right to make changes judged to be necessary.



**STRAIGHT PLUG CLAMP TYPE**

**CABLE 2.6/50+75 S**

**R114.005.000**

Series : SMB

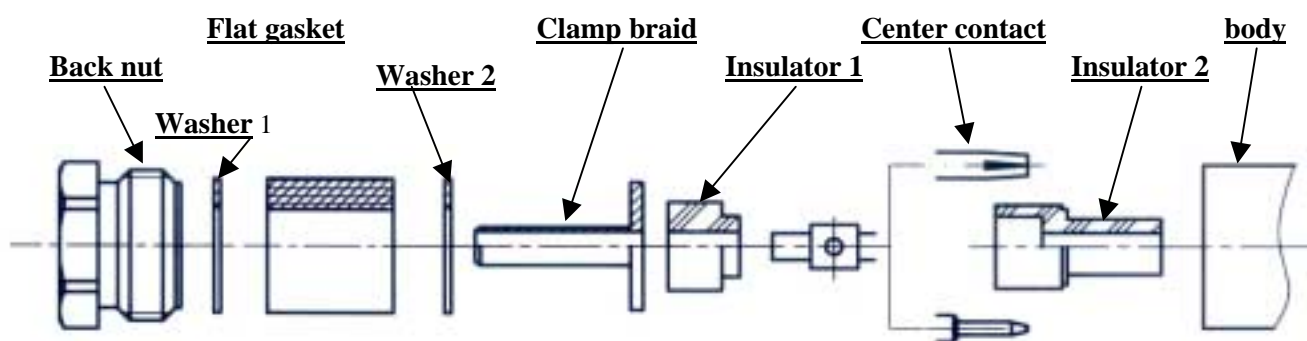

**1**

Slide the back nut, the washer 1, the flat gasket, the washer 2 onto the cable.  
Strip the cable.  
Cut 2 slots in the jacket if necessary.

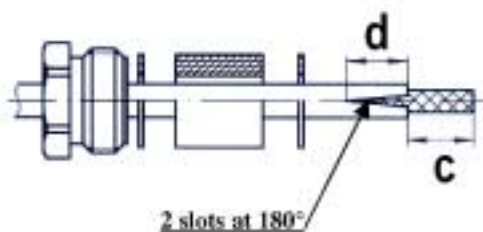

**3**

Slide the first insulator.  
Slide the center contact and solder.  
Slide the second insulator

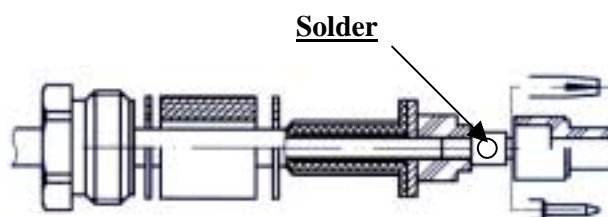

**2**

Slide the clamp braid sleeve.  
Cut the braid flush with the clamp braid sleeve.  
Strip off the diélectric.

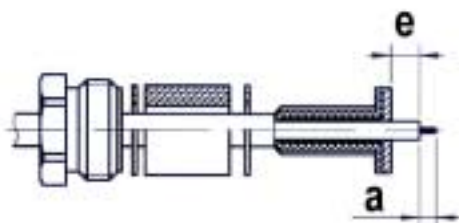

**4**

Screw sub-assembly into the connector body with the adapted wrench.  
Recommended coupling torque ( see connector TDS ).

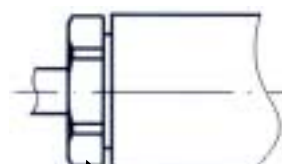

**Hex. : see connector TDS**

**Issue : 0721 T**

In the effort to improve our products, we reserve the right to make changes judged to be necessary.

