

STRAIGHT CONNECTOR C-C FEMALE CRIMP TYPE
CABLE 3.6/75 DOUBLE SCREEN PACK 20

Series : TYPE 43

1 / 2

SHN

SOCKET 43/5FS

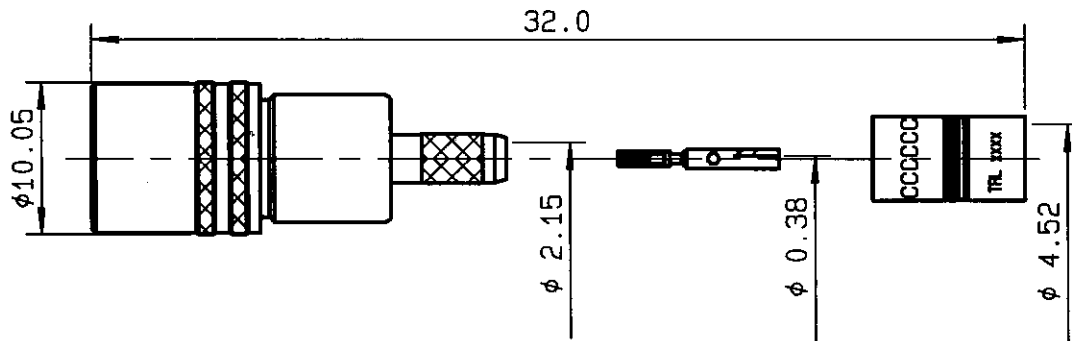

CABLES : BT3002/POPE46431

CHARACTERISTICS

NOMINAL IMPEDANCE	75	Ω
FREQUENCY RANGE	0-3	GHz
TEMPERATURE RATING	-40/+100	$^{\circ}\text{C}$
VSWR	NA +	- x F(GHz)Max1
RF INSERTION LOSS	NA	$\sqrt{F(\text{GHz})}$ dB Max1
VOLTAGE RATING	500	Vrms Max
DIELECTRIC WITHSTANDING VOLTAGE	1500	Vrms min
INSULATION RESISTANCE	500	M Ω min
HERMETIC SEAL	NA	Atm.cm3/s
LEAKAGE (pressurized only)	NA	Mpa
WEIGHT	10	gr

APPLICABLE STANDARDS

CABLE RETENTION	150	N min
CENTER CONTACT RETENTION		
Axial force - mating end	22	N min
Axial force - opposite end	NA	N min
Torque (Min)	NA	cm.N min
RECOMMENDED TORQUES		
Mating	NA	cm.N
Panel nut	NA	cm.N
Clamp nut	NA	cm.N

CONSTRUCTION

CONNECTOR PARTS	MATERIALS	FINISH
BODY	BRASS	NICKEL
OUTER CONTACT	BRONZE	GOLD
CENTER CONTACT	BERYLLIUM COPPER	GOLD
INSULATOR	PTFE	-
COUPLING SLEEVE	BRASS	NICKEL
FERRULE	BRASS	NICKEL
-	-	-
-	-	-
-	-	-

ISSUE	REVISION No	DESCRIPTION	BY	DATE
-	-	-	-	-
-	-	-	-	-
-	-	-	-	-

Initiated on 23/09/94

The information given here is subject to change without notice. Design changes may be in order to improve the product.



Approval by MARTIN

SHN

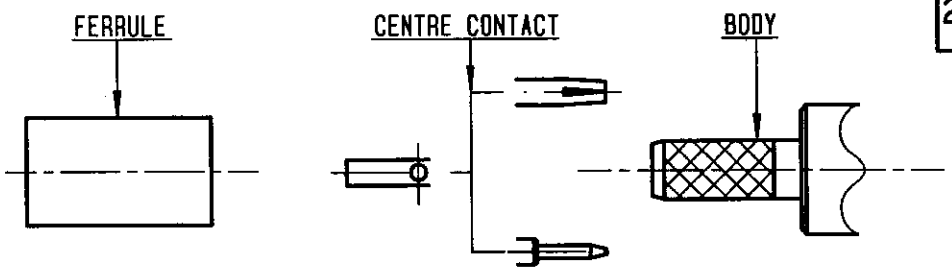

①

Slide ferrule onto cable.
Strip cable.

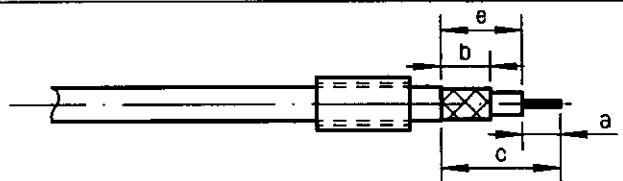

Stripping	a	b	c	d	e
inch	0.177	0.315	0.827	0	0.65
mm	4.5	8	21	-	16.5

②

Place centre contact on conductor.
(ensure conductor is visible through inspection hole).
Place adaptor in crimp tool.
Insert cable into adaptor. Push home.
Crimp centre contact.
Crimp tool R282 281 010 (Q92434)

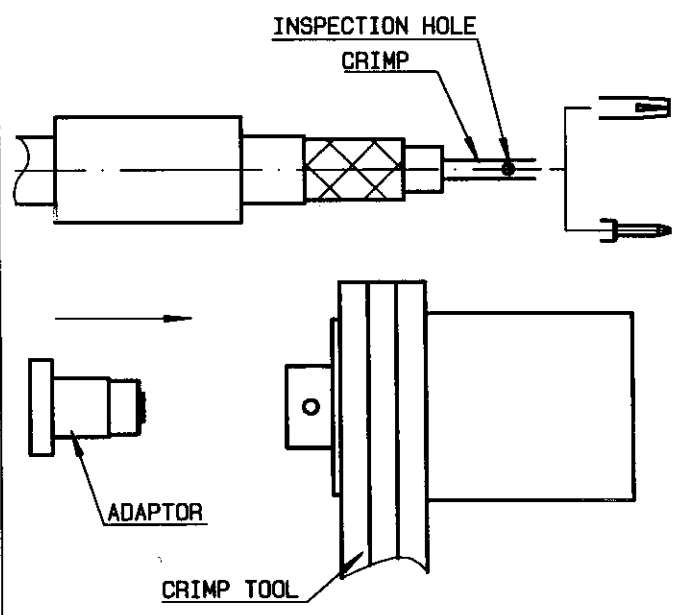

③

Guide dielectric into connector while fanning braid. Push home until centre contact 'clicks' into place.

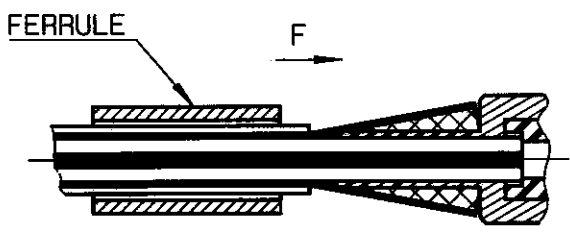

④

Slide crimp sleeve forward until sleeve butts up against body.
Crimp ferrule.
Crimp tool R282 287 000 (Q92316) +
die set R282 265 002 (Q92435) (Hex. 4.52).

